

Reference Manual

P DM 5340

SD / HD / 3 GBit/s Multi-format analog Audio
Embedder / Deembedder

Revision: 1.1
August 2013

This Manual Supports Device Revisions:	
P DM 5340 Firmware Revision	529
Control System GUI Release	6.2.1

Information in this document is subject to change without notice. No part of this document may be reproduced or transmitted in any form or by any means, electronic or mechanical for any purpose, without express written permission of LYNX Technik AG.

LYNX Technik AG may have patents, patent applications, trademarks, copyrights or other intellectual property rights covering the subject matter in this document. Except as expressly written by LYNX Technik AG, the furnishing of this document does not give you any license to patents, trademarks, copyrights or other intellectual property of LYNX Technik AG or any of its affiliates.

LYNX Technik AG
Brunnenweg 3
D 64331 Weiterstadt
Germany
www.lynx-technik.com

Contents

REGULATORY INFORMATION.....	5
EUROPE.....	5
USA.....	5
GETTING STARTED	6
PACKAGING	6
ESD WARNING.....	6
<i>Preventing ESD Damage</i>	6
PRODUCT DESCRIPTION.....	7
KEY FEATURES.....	7
INPUT FORMATS.....	8
OUTPUT FORMATS	8
AUDIO PROCESSING.....	9
AUDIO MONO CROSSBAR	9
AUDIO GROUP DELETION	9
FUNCTIONAL DIAGRAM (P DM 5340).....	9
MODULE LAYOUT	10
CONNECTIONS	11
VIDEO.....	11
AUDIO.....	11
INSTALLATION.....	12
SETTINGS AND CONTROL.....	13
SWITCH SETTINGS.....	14
<i>Switch Function Detail.....</i>	14
<i>Factory Preset Condition.....</i>	15
<i>Auto Store.....</i>	15
<i>Reset Button</i>	15
ALARM/LED STATUS INDICATORS	16
<i>SDI Status</i>	16
<i>Audio Status.....</i>	16
<i>Power Indication.....</i>	17
<i>Local/remote LED</i>	17
CONTROL SYSTEM GUI.....	18
MAIN TAB	19
<i>Group Status</i>	19
<i>Audio Crossbars.....</i>	20
<i>Embedder</i>	20

<i>Audio Outputs</i>	20
<i>Full Scale level for A/D and D/A conversion</i>	20
AES PROCESSING TAB	21
AUDIO PORT SETUP	22
EVENTS TAB	23
<i>Log in GUI Function</i>	23
<i>Event Enabled</i>	23
<i>SNMP Support</i>	23
COMMON GUI CONTROLS	24
<i>Properties</i>	24
<i>Locate</i>	24
<i>New Control Window</i>	25
<i>Rename</i>	25
<i>Save Settings Now</i>	25
<i>Lock</i>	25
<i>Reset Factory Defaults</i>	26
SPECIFICATIONS	27
SERVICE	28
PARTS LIST	28
TECHNICAL SUPPORT	28
CONTACT INFORMATION	28

Warranty

LYNX Technik AG warrants that the product will be free from defects in materials and workmanship for a period of three (3) years from the date of shipment. If this product proves defective during the warranty period, LYNX Technik AG at its option will either repair the defective product without charge for parts and labor, or will provide a replacement in exchange for the defective product.

In order to obtain service under this warranty, customer must notify LYNX Technik of the defect before expiration of the warranty period and make suitable arrangements for the performance of service. Customer shall be responsible for packaging and shipping the defective product to the service center designated by LYNX Technik, with shipping charges prepaid. LYNX Technik shall pay for the return of the product to the customer if the shipment is within the country which the LYNX Technik service center is located. Customer shall be responsible for payment of all shipping charges, duties, taxes and any other charges for products returned to any other locations.

This warranty shall not apply to any defect, failure, or damage caused by improper use or improper or inadequate maintenance and care. LYNX Technik shall not be obligated to furnish service under this warranty a) to repair damage resulting from attempts by personnel other than LYNX Technik representatives to install, repair or service the product; b) to repair damage resulting from improper use or connection to incompatible equipment; c) to repair any damage or malfunction caused by the use of non LYNX Technik supplies; or d) to service a product which has been modified or integrated with other products when the effect of such modification or integration increases the time or difficulty servicing the product.

THIS WARRANTY IS GIVEN BY LYNX TECHNIK WITH RESPECT TO THIS PRODUCT IN LIEU OF ANY OTHER WARRANTIES, EXPRESS OR IMPLIED. LYNX TECHNIK AND ITS VENDORS DISCLAIM ANY IMPLIED WARRANTIES OF MERCHANTABILITY OR FITNESS FOR A PARTICULAR PURPOSE. LYNX TECHNIK'S RESPONSIBILITY TO REPAIR AND REPLACE DEFECTIVE PRODUCTS IS THE SOLE AND EXCLUSIVE REMEDY PROVIDED TO THE CUSTOMER FOR BREACH OF THIS WARRANTY. LYNX TECHNIK AND ITS VENDORS WILL NOT BE LIABLE FOR ANY INDIRECT, SPECIAL, INCIDENTAL, OR CONSEQUENTIAL DAMAGES IRRESPECTIVE OF WHETHER LYNX TECHNIK OR THE VENDOR HAS ADVANCE NOTICE OF THE POSSIBILITY OF SUCH DAMAGES.

Regulatory information

Europe

Declaration of Conformity

We	LYNX Technik AG Brunnenweg 3 D-64331 Weiterstadt Germany
<i>Declare under our sole responsibility that the product</i>	
TYPE: P DM 5340	
<i>To which this declaration relates is in conformity with the following standards (environments E1-E3):</i>	
EN 55103-1 /1996	
EN 55103-2 /1996	
EN 60950-1 /2006	
<i>Following the provisions of 89/336/EEC and 73/23/EEC directives.</i>	
	Winfried Deckelmann
Weiterstadt, April 2013	
<i>Place and date of issue</i>	<i>Legal Signature</i>

USA

FCC 47 Part 15

This device complies with part 15 of the FCC Rules. Operation is subject to the following two conditions: (1) This device may not cause harmful interference, and (2) this device must accept any interference received, including interference that may cause undesired operation.

Note: This equipment has been tested and found to comply with the limits for a Class A digital device, pursuant to the part 15 of the FCC Rules. These limits are designed to provide reasonable protection against harmful interference when the equipment is operated in a commercial environment. This equipment generates, uses, and can radiate radio frequency energy and, if not installed and used in accordance with the instruction manual, may cause harmful interference to radio communications. Operation of this equipment in a residential area is likely to cause harmful interference in which case the user will be required to correct the interference at his own expense

Getting Started

Most CardModules are installed into the rack frames and system tested in the factory. If this is an upgrade part or service exchange item then the module is supplied in a padded cardboard carton which includes the CardModule, rear connection plate and mounting screws.

Packaging

The shipping carton and packaging materials provide protection for the module during transit. Please retain the shipping cartons in case subsequent shipping of the product becomes necessary. Do not remove the module from its protective static bag unless observing adequate ESD precautions. Please see below.

ESD Warning



This product is static sensitive. Please use caution and use preventative measures to prevent static discharge or damage could result to module.

Preventing ESD Damage

Electrostatic discharge (ESD) damage occurs when electronic assemblies or the components are improperly handled and can result in complete or intermittent failure.

Do not handle the module unless using an ESD-preventative wrist strap and ensure that it makes good skin contact. Connect the strap to any solid grounding source such as any exposed metal on the rack chassis or any other unpainted metal surface.

Caution

Periodically check the resistance value of the antistatic strap. The measurement should be between 1 and 10 MegOhms.

Product Description

The P DM 5340 is a high quality 3GBit/s analog audio embedder and de-embedder suitable for use in SDTV applications and new HDTV applications, with support for a variety of HDTV formats.

The 2 audio stereo ports can be individually configured by the user as audio inputs or outputs. Already embedded audio can be de-embedded internally and routed through an audio mono crossbar in parallel to up to four external audio inputs.

The module is multi-format (3GBit/s, HD and SD) and multimode in operation. The input video standard (and format) is detected and the module automatically switches its operation to the detected format.

The module also provides 2 x SDI outputs so it can also fill the role of a multi-format 1 > 2 re-clocking distribution amplifier.

The module provides support for balanced analog audio inputs or outputs on a 25 pin SubD connection plate.

Note. *The P DM 5340 is shipped as a 2 x analog stereo audio Embedder (factory default). To configure audio stereo ports as outputs (deembedder function), please use GUI application (APPolo Control) (see page 22).*

Note. *Please check connected peripheral equipment before using the P DM 5340 to make sure the audio ports of the P DM 5340 are configured correctly, e.g. an output is not connected to an output of another device, this might damage the equipment.*

Key Features

- Support for SDTV, HDTV and 3GBit/s standards
- Automatic video standard and format detection
- Audio ports can be individually configured as inputs or outputs
- Existing embedded audio can be deembedded
- Delete or replace existing embedded audio
- Mono audio crossbar
- Audio processing (mono gain, test tone, mute, phase invert, mix, overload and silence detection)
- Embedded audio group selection
- 2 x SDI outputs
- Selectable Horizontal and Vertical Video Blanking

Input Formats

The module has one multi-format serial digital input with automatic input detection. The module will detect the following input standards and configure the module automatically for operation in the connected format.

SDTV Formats	HDTV Formats	3GBit/s (Level A) Formats
525 / 59.94Hz	1080i / 50Hz	1080p / 50Hz
625 / 50Hz	1080i / 59.94Hz	1080p / 59.94Hz
	1080i / 60Hz	1080p / 60Hz
	1080p / 23.98Hz	
	1080p / 24Hz	
	1080p / 25Hz	
	1080p / 29.97Hz	
	1080p / 30Hz	
	1080psf / 23.98Hz	
	1080psf / 24Hz	
	1080psf / 25Hz	
	720p / 23.98Hz	
	720p / 24Hz	
	720p / 25Hz	
	720p / 29.97Hz	
	720p / 30Hz	
	720p / 50Hz	
	720p / 59.94Hz	
	720p / 60Hz	

Output Formats

Same as the input format, or the pre-selected format if no input is connected (see above).

Audio Processing

All internal and external audio signals can be processed in an audio processing stage including mono gain, phase invert, test tone, stereo mix down as well as overload and silence detection.

Audio Mono Crossbar

All audio signals (external and deembedded) are fed into a monaural audio crossbar where individual left and right audio channels can be re-assigned / swapped prior to embedding.

Note. The mono switching function is only accessible using the Module GUI via the control system. The local menu system and display only allows for switching of stereo pairs

Audio Group Deletion

The P DM 5340 will detect any audio groups present in the SDI stream, and each group can be selected individually. The user has the choice of passing any existing embedded audio group(s) intact, replacing the audio group(s) or deleting the audio group(s).

Functional Diagram (P DM 5340)

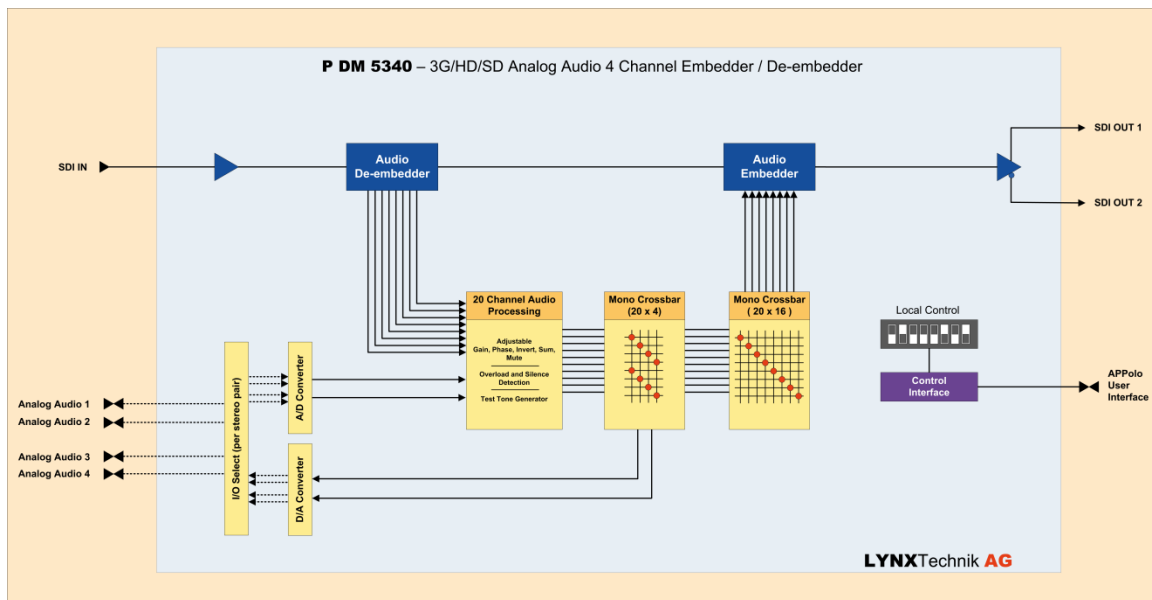

Note. The P DM 5340 is shipped as a 2 x analog stereo audio Embedder (factory default). To configure audio stereo ports as outputs (deembedder function), please use GUI application (APPolo Control) (see page 22).

Note. Please check connected peripheral equipment before using the P DM 5340 to make sure the audio ports of the P DM 5340 are configured correctly, e.g. an output is not connected to an output of another device, this might damage the equipment.

Module Layout

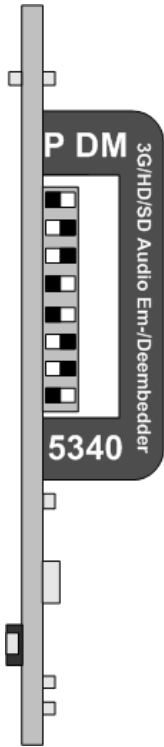

Module Front Panel

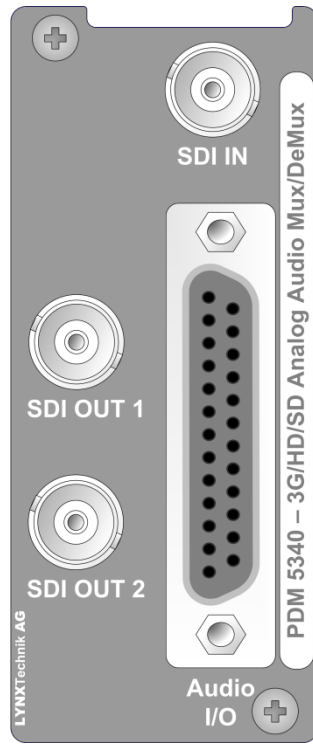

Module Rear Termination Panel

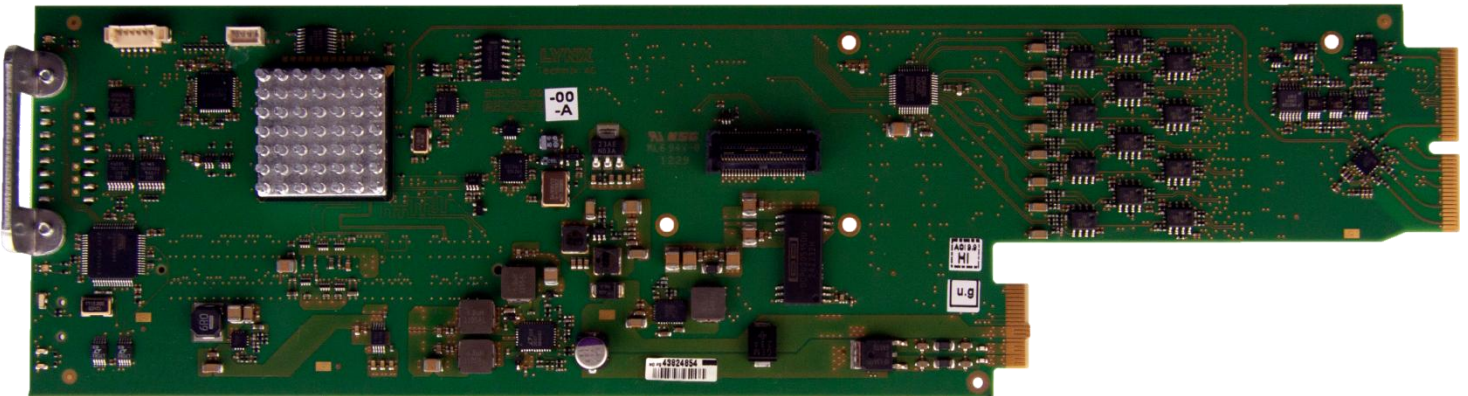

CardModule Layout

Connections

Video

The P DM 5340 uses standard 75 Ohm BNC connectors. We recommend the use of high quality video cable for digital video connections to reduce the risk of errors due to excessive cable attenuation. Max cable lengths the module will support are shown below.

SDTV = 250m Belden 8281 (270Mbits/s)

HDTV = 140m Belden 1694A (1.4Gbits/s)

3Gbit/S = 80m Belden 1694A (2.97Gbits/s)

Note. Due to the compact design of the connection plate it will be necessary to use a connection tool to secure the BNC video connectors.

Audio

The module is provided with a rear connection plate with a 25 pin female SubD connection for balanced audio signals. Connector wiring is shown below.

Pin Number	Connection	Pin Number	Connection
1			
2			
3			
4			
5			
6			
7	Audio 2R +	20	Audio 2R -
8	Audio 2R GND	21	Audio 2L +
9	Audio 2L -	22	Audio 2L GND
10	Audio 1R +	23	Audio 1R -
11	Audio 1R GND	24	Audio 1L +
12	Audio 1L -	25	Audio 1L GND
13	n.c.		

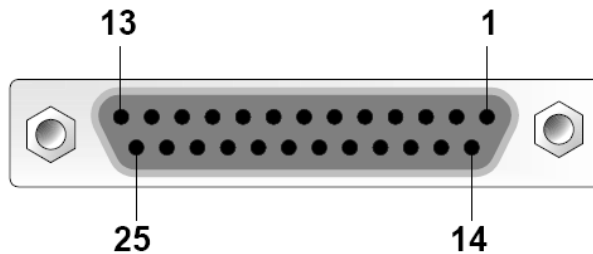

View looking INTO connector as seen on module

We recommend you use high quality screened (twisted pair) cable for the balanced audio connections. LYNX has an optional audio breakout cable which will bring out all audio connections to in line XLR connectors. Model number **R AC M 25-8** or **R AC F 25-8**

Installation

If this module was supplied as part of a system it is already installed in the rack enclosure. If the module was supplied as a field upgrade please follow the installation procedure below.



NOTE Observe static precautions when handling card. Please see ESD warnings on Page 6.

Each Card Module is supplied with a rear connection panel and two mounting screws. Please follow the following procedure for installation of the card module into the Series 5000 Card Frame.

1. Select a slot in the card frame where the CardModule will be located.
2. Remove the blank connection panel from the rear of the rack (if fitted)
3. Install the rear connection panel using the screws supplied. Do not tighten the screws fully
4. Slide the card module into the card frame and carefully check the CardModule connects to the rear connection plate. The card should fit easily and should not require excessive force to insert, if you feel any resistance, there could be something wrong with the rear connection panel location. Do not try and force the connection this may damage the connectors. Remove the rear connection panel and check alignment with the CardModule.
5. Insert and remove the CardModule a few times to ensure correct alignment and then tighten the two screws to secure the rear connection plate.

Settings and Control

The P DM 5340 has an integrated micro-controller, which enables the module to be configured and controlled locally via the dip-switch or from remote when using one of the optional controllers and control software.

Once set, all settings are automatically saved in non-volatile internal memory. (Flash RAM) The module will always recall the settings used prior to power down.

PCB Front View

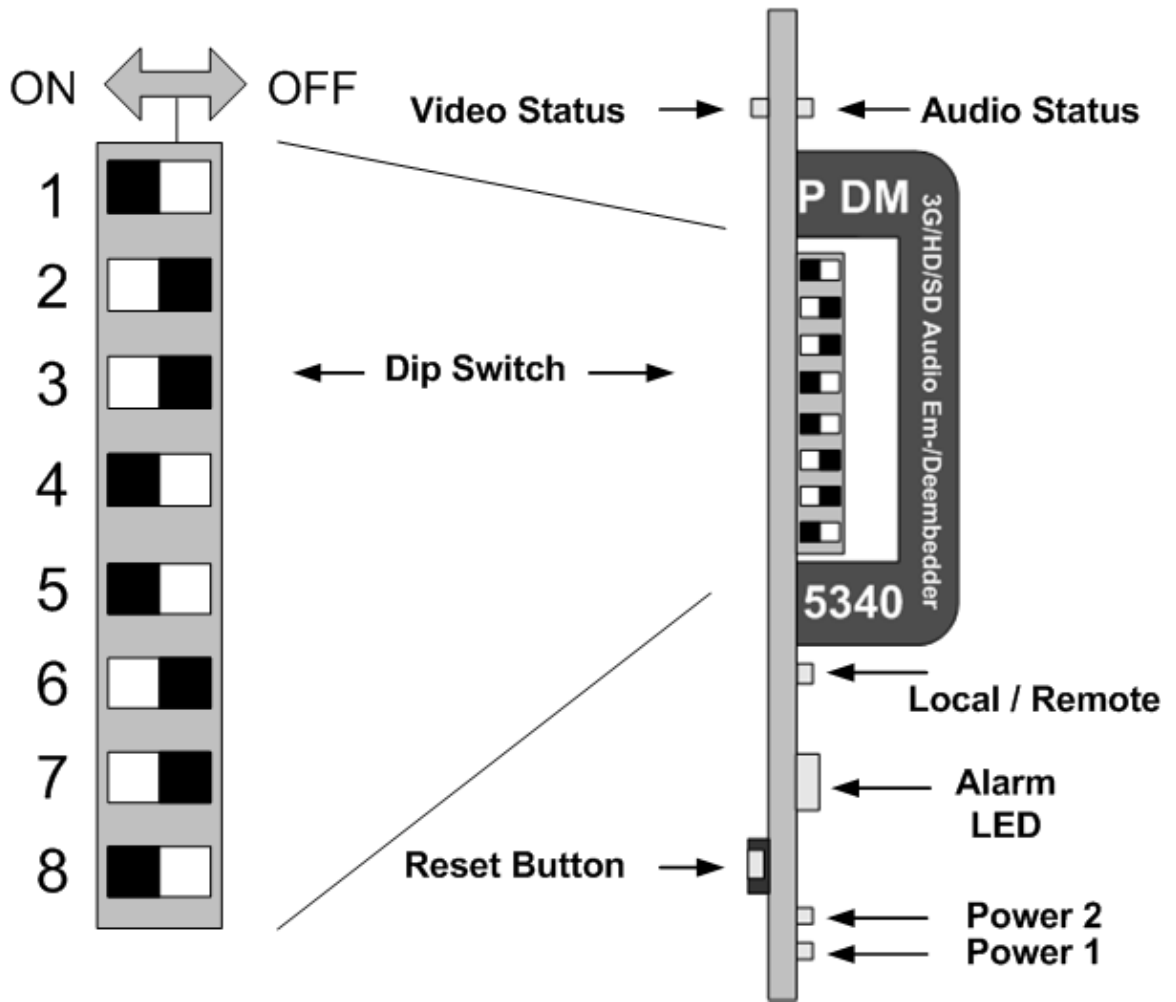

Switch and LED locations

Switch Settings

Below the switch settings for the 8-position dip-switch are defined.

Switch	Setting	Function
1	ON	Enable Local Adjustment
	OFF	Disable Local Adjustment
2	ON	Audio Embedder for Group 1 active
	OFF	No Embedding for Audio Embedder Group 1
3	ON	Audio Embedder for Group 2 active
	OFF	No Embedding for Audio Embedder Group 2
4	ON	Audio Embedder for Group 3 active
	OFF	No Embedding for Audio Embedder Group 3
5	ON	Audio Embedder for Group 4 active
	OFF	No Embedding for Audio Embedder Group 4
6	ON	Erase content in H-Blanking interval
	OFF	Content in H-Blanking interval preserved
7	ON	Erase content in V-Blanking interval
	OFF	Content in V-Blanking interval preserved
8		

Switch Function Detail

Dip Switch 1

This switch is used to enable or disable local adjustments. Set to **ON** enables the setting of the other dip switches to configure the module. Set to **OFF** will prevent any switch settings taking effect.

Note. It is recommended to set it to **OFF** to prevent accidental changes to the stored module configuration if the switches are moved.

Dip Switch 2

This switch configures audio embedder for group 1. **ON** enables the embedder, new audio is then embedded into the SDI signal. Already embedded audio of group 1 will be overwritten, **OFF** disables the embedder, already embedded audio in the SDI signal will be preserved

Dip Switch 3

This switch configures audio embedder for group 2. **ON** enables the embedder, new audio is then embedded into the SDI signal. Already embedded audio of group 2 will be overwritten, **OFF** disables the embedder, already embedded audio in the SDI signal will be preserved

Dip Switch 4

This switch configures audio embedder for group 3. **ON** enables the embedder, new audio is then embedded into the SDI signal. Already embedded audio of group 3 will be overwritten, **OFF** disables the embedder, already embedded audio in the SDI signal will be preserved

Dip Switch 5

This switch configures audio embedder for group 4. **ON** enables the embedder, new audio is then embedded into the SDI signal. Already embedded audio of group 4 will be overwritten, **OFF** disables the embedder, already embedded audio in the SDI signal will be preserved

Dip Switch 6

If this Dip Switch is set to ON all content in the horizontal blanking intervals will be erased
If set to OFF the content in the horizontal blanking intervals will be preserved

Dip Switch 7

If this Dip Switch is set to ON all content in the vertical blanking intervals will be erased
If set to OFF the content in the vertical blanking intervals will be preserved

Factory Preset Condition

The P DM 5340 is delivered programmed and preset for the following mode of operation:

Switch 1 **ON** Local Adjustment Enabled

Switch 2 -5 **ON** Embedders for Group 1..4 enabled

Switch 6 **OFF** Content in H-Blanking interval preserved

Switch 7 **OFF** Content in V-Blanking interval preserved

If this is the required mode of operation, then no adjustments are necessary.

Auto Store

If no parameters are changed for 10 seconds then the current settings will be written into the flash memory automatically. This can be seen by the channel status LEDS flashing yellow three times.

Reset Button

If this button is pressed for 5 seconds all parameters will be reset to their factory default settings. To confirm this reset, the device will blink all LEDs once (OFF – ON – OFF) and then return to their normal state.

Alarm/LED Status Indicators

The P DM 5340 module has integral LED indicators, which serve as alarm and status indication for the module. Function is described below.

SDI Status

This LED indicates the status of the SDI input signal

LED Color	Indication
Green	SDI present and ok
Yellow	SDI o.k, but unsupported standard, no embedding takes place
Red	No valid SDI standard

Audio Status

This LED indicates the status of the audio input signals

LED Color	Indication
Green	All used audio inputs present and o.k.
Yellow	Warning condition. Any of: - At least one embedded group is missing one AES signal and Embedder event enabled. - At least one external Audio Input is missing but routed to be embedded.
Red	Error condition. Any of: - At least one external Audio Input has no signal. - At least one embedded group is missing both AES signals and Embedder event is enabled.

Alarm Indicator

There is also a single alarm LED on the lower edge of the module (figure 3). This is visible through the card frame front cover and provides a general indication of the module status.

LED Color	Indication
Green	External Audio Output: - All audio output pairs have two audio channels Embedder: - Each selected embedded group has all four possible audio channels.
Yellow	External Audio Output: - At least one of the audio output pairs is missing one audio channel Embedder: - At least one of the selected embedded groups is missing one, two and/or three of the possible four audio channels.
Red	External Audio Output: - At least one audio output pair is missing both possible audio channels. Embedder: - At least one embedded group is missing all four possible audio channels

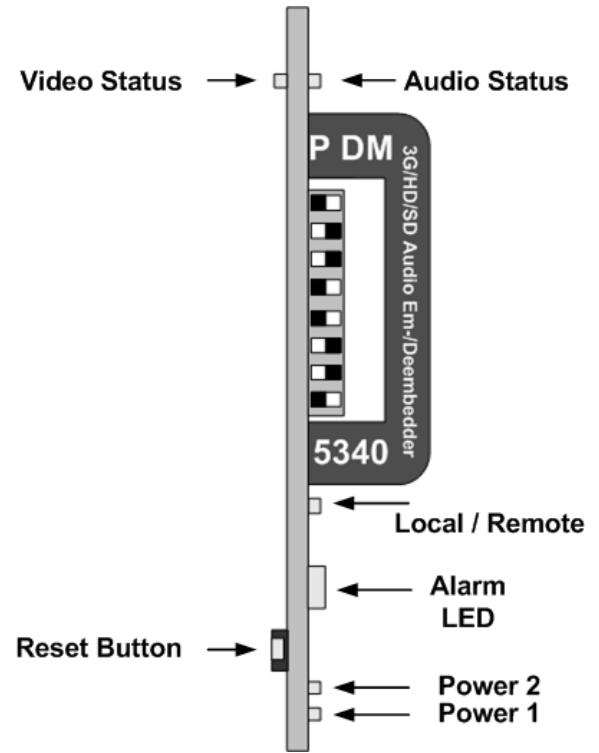

Power Indication

There are two LEDs on the lower edge of the module indicating the presence of the two power supply voltages (main power supply and redundant power supply).

LED 1	Indication
Green	Power from Main PSU ok
off	No power from Main Power Supply

LED 2	Indication
Green	Power from Redundant PSU ok
off	No power from Redundant PSU

Local/remote LED

LED Color	Indication
Green	Local control via DIP switches active, all settings according to local DIP switches
off	Current settings may be overwritten through remote control

Control System GUI

All LYNX CardModules support a computer interface which allows setting the modules parameters using a simple GUI interface. Access to all standard features (and in some cases) extended features is possible using this interface.

Access to the GUI requires the use of the optional LYNX control system

Note. Any settings made using the control system overrides any local settings made on the module. All settings are stored in internal flash ram and will survive power cycles and long term storage.

The GUI screenshots below are for the P DM 5340 module.

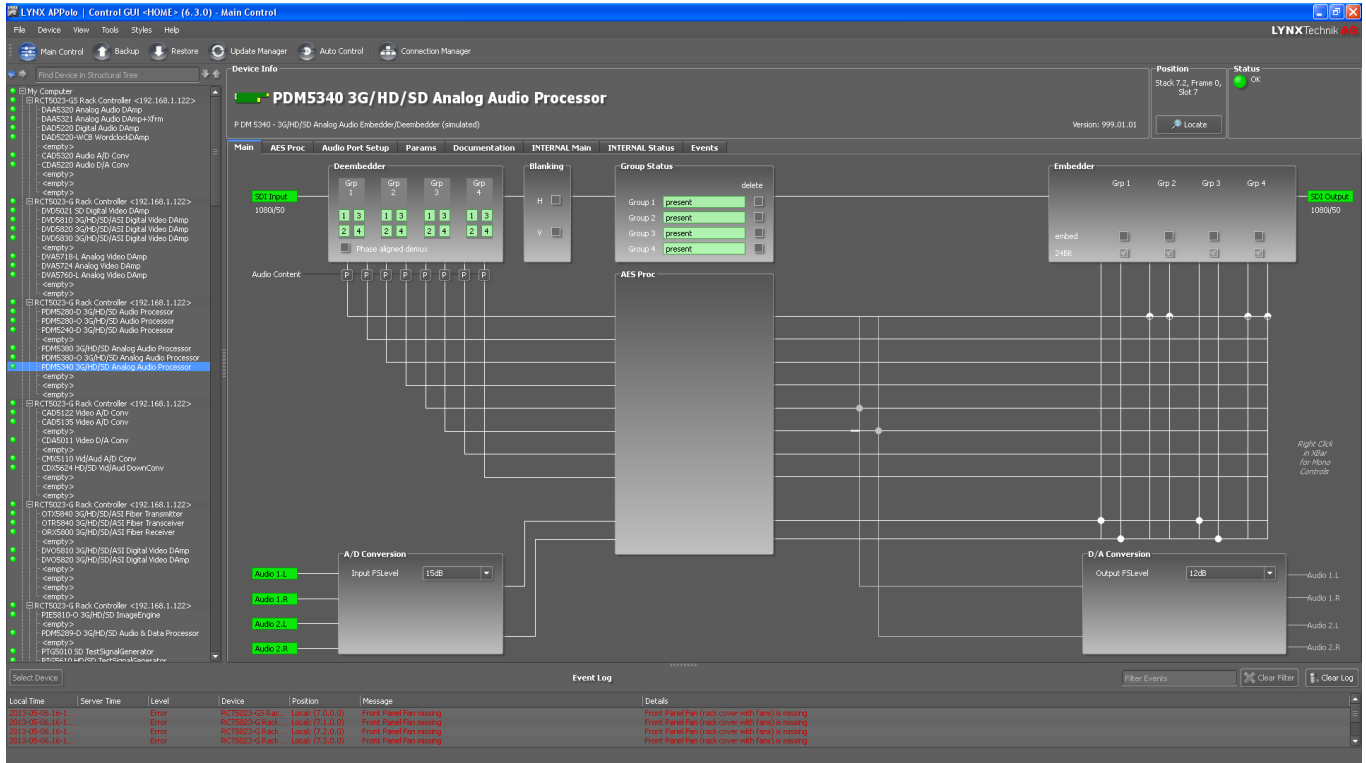

The above screenshot shows the complete module GUI. The Device info area contains information about the module including name and firmware revision. If used as part of a larger system (using the LYNX central control system) the modules position and physical location is displayed above the “locate” button.

Note. The Locate function is a tool used to quickly identify a module in larger systems. Selecting “locate” will flash the module alarm LED yellow. (does not effect module operation). This function will be automatically stopped (timeout)

The first screen you see when the module is selected is the **Main** tab this is a graphical representation of the modules function and signal flow (left to right). Clicking on processing boxes where shown will link to other GUI screens with controls for these specific functions.

The area at the bottom of the screen is the error log. Any fault condition will be time stamped and entered into the log.

There are a number of Tabs associated with each Module which splits up the modules settings into a number of separate screens. The primary GUI screens and functions are described below.

Main Tab

This screen is the main GUI interface and is presented first when the module is displayed in the GUI. The layout replicates module function and the signal flow if from left to right. Selections are made using onscreen sliders, radio buttons, drop down selections and checkboxes.

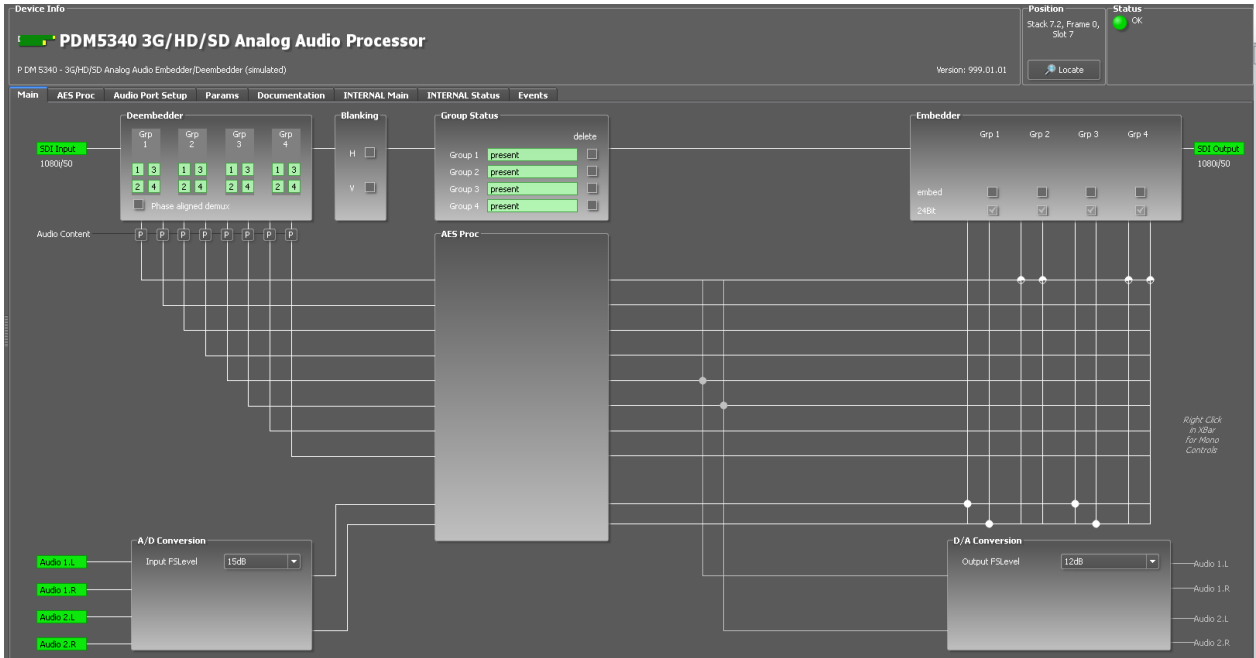

Input Detection

On the left the SDI input and the Audio inputs are detected. The standard / format of the SDI signal is displayed on screen in green (if format is not supported then the color is YELLOW and if input is missing the color is RED).

If a valid audio signal is detected the audio input detection turns GREEN, a missing audio signal will be indicated in RED. Audio ports which are configured as outputs are greyed out in the input section.

Note: Input and outputs signals can be renamed by the user. Simply right click on the signal name and specify a user defined signal name



Group Status

Any embedded audio is detected and the status is displayed in the Group Status area. If embedded audio is present it will highlight green. It is possible to delete each incoming audio group individually at this stage using the delete checkbox.

Note. If the audio is not deleted but the group is selected for embedding then the existing audio will be over written.

Audio Crossbars

Each audio input as well as each deembedded AES signal passes into a mono crossbar where each individual left and right channel is split from the AES inputs and made available for mapping into any of the available crossbar outputs for activated audio outputs and the embedder feeds.

Embedder

The crossbar provides 8 audio stereo outputs combined into 4 AES groups which can be embedded into the SDI input stream. Group selection is possible using the group select checkbox.

Note. *If an existing embedded group has not been deleted but is selected for embedding then the existing audio will be overwritten*

If an HDTV or 3GBit/s input signal is detected then only signals with 24 Bit audio will be embedded. If an SDTV signal is detected then you can select in between 20 and 24 Bit embedding.

Audio Outputs

If audio ports are configured as outputs the selection matrix for the respective cross points will be activated. Also the respective audio outputs will be highlighted.

If AES ports are configured as inputs the respective cross points and the audio outputs are greyed out.

Full Scale level for A/D and D/A conversion

The required audio full scale levels can be adjusted for the input A/D conversion and the output D/A conversion. To avoid level changes through conversion, the full scale level on the input and output conversion should be set to the same level.

AES Processing Tab

All audio signals (external and deembedded AES) can be individually processed

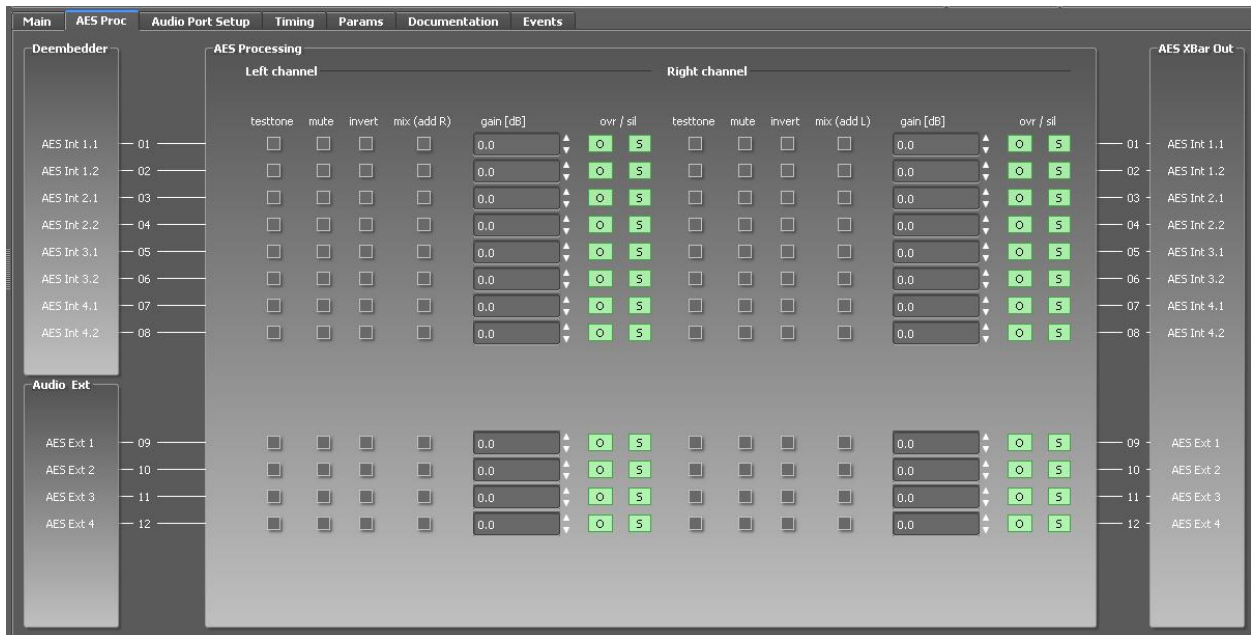

The following functions are provided:

- Left and Right Test Tone
- Left and Right MUTE
- Left and Right PHASE INVERT
- Left and Right mix
- Left and right GAIN (0dB .. -66.3dB)
- Overload and Silence detection for Left and Right

Audio Port Setup

In this tab the ports can be configured. Configuration is for audio stereo signals (Left and Right). The configuration is locked automatically when the tab is closed and the selections to configure the individual ports are greyed out.

To change a configuration the check box “Unlock Audio Port Settings” has to be activated.

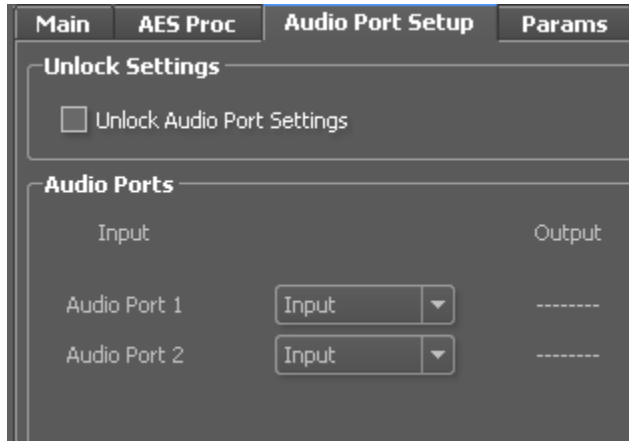

Note. The P DM 5340 is shipped as a 2 x Audio Stereo Embedder (factory default).

Note. Please check connected peripheral equipment before using the P DM 5340 to make sure the audio ports of the P DM 5340 is configured correctly, e.g. an output is not connected to an output of another device, this might damage the equipment.

Events Tab

The Events Tab is where the module alarming and error notifications are configured for the module.

The GUI has an integrated error log, which is a simple text log file stored in the controller PC. This will record an event and timestamp it. The log can be seen at the bottom of the GUI screen and can be scrolled through using the scrolling bar.

Log in GUI Function

Events are selectable, you can chose if you want to record a particular event in the log (or not) or configure it to only record one side of the event. (*For example you might want to log when a SDI input is removed but do not want to log when it comes back*). The ON/OFF trigger can be configured for each of the available events shown in the list and is setup using the checkboxes provided.

Event Enabled

By default all alarm conditions are activated (checked), by de-selecting a specific alarm condition in this column you are telling the module to ignore this condition completely. It will not color the alarm LED, log and event in the GUI or send a SNMP trap. This is useful if for example you never have anything connected to AES input 4 and want the card to ignore this input condition completely then you would simply de-select "AES 4 Input: No input" and it will be ignored.

SNMP Support

If the system is using a RCT 5031 Master Controller or OH_RCT5024 Server and the SNMP option is installed then the "SNMP Trap" columns become available.

Here you can configure for which events you would like to transmit a "SNMP trap" over the network. (This has no impact or influence over the internal error log maintained by the LYNX control system)

(Internal LYNX error logging and external SNMP traps can be configured independently).

Common GUI Controls

There are a number of GUI controls and commands which are common for all modules in the control system. These are explained below.

Right click on any module in the tree will bring up a sub-menu of available commands (see below). **Note.** This menu can also be selected using the GUI drop down menus by clicking on **“Device”**

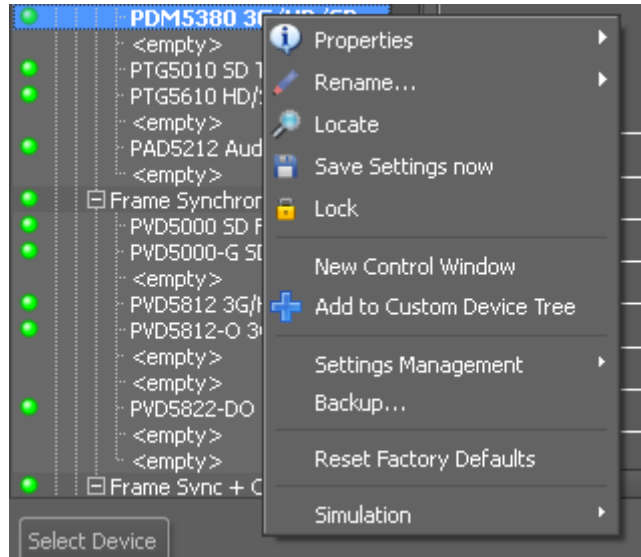

Properties

This will bring up a dialog which shows device specific properties about the module selected.

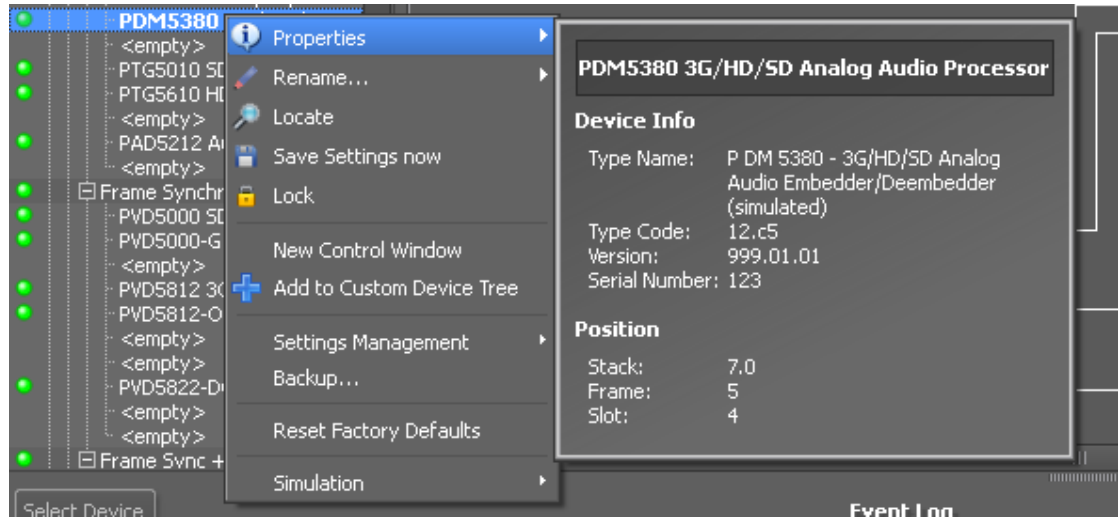

Locate

This feature is useful if you need to physically locate a module in a larger system quickly (for removal or maintenance purposes) When Locate selected this will flash the module alarm LED yellow. This function does not impact normal module operation and will timeout after a short time period.

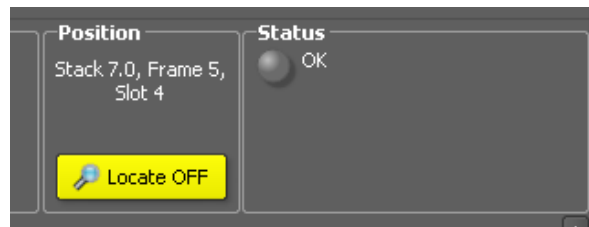

This feature can also be invoked from the main GUI screen using the “locate“ button in the top right hand side of the screen (see below)

New Control Window

Selecting this will open up a new control window with the selected module GUI contained within. This window can be minimized to the taskbar for fast access and is useful if this GUI is something you will need to refer to often.

Rename

It is possible to rename individual items in the control system selection tree, this includes all rack names and the individual module names. The descriptions supplied are default descriptions the system applies. To rename a device simply select the device in the tree, right click and then select “rename”. The dialog below will be displayed

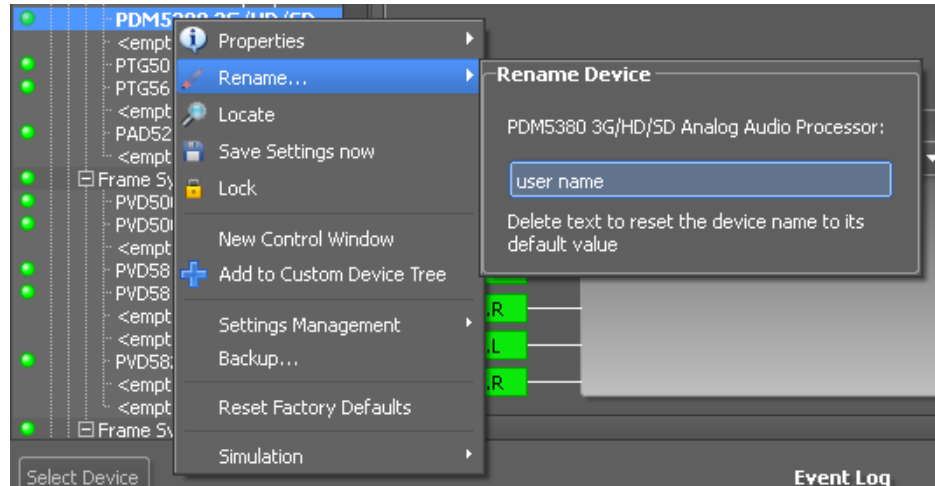

Simply type in the name you wish to assign to this device and press RETURN. If you wish to restore the default name simply delete the content in the text field and press RETURN

Note: The names are stored inside the flash memory of a LYNX server (if installed) or the hard disk of the connected Computer.

Save Settings Now

During normal operation if there is no activity on the module GUI for approx.. ten seconds then any changed settings are automatically written to flash RAM in the module. You can store the settings immediately by using the “save settings now” command. When the settings have been stored you will see the confirmation dialog below.

It is recommended you use the “save settings now” function before removing any module from the rack to ensure the latest settings have been stored prior to module removal (if a module is removed before the normal 10 second timeout then the settings will not be stored)

Lock

Selecting this will lock the device to prevent any accidental changes being made to the modules settings. The module status can be seen but all the controls will be grayed out. To unlock simply deselect the lock control from the menu.

Reset Factory Defaults

If you are unsure of the settings, or have managed to set the module into a strange mode of operation and wish to recover the factory defaults then this can be done by selecting reset factory defaults. You will be asked to confirm this operation with the dialog below



Specifications

Video Input	
Signal Type	Serial Digital Video (SDI) SMPTE 292M, 259M, 424 M with automatic input standard and format detection
Supported Formats	See page 8
Input Impedance	75 Ω BNC
Input Level	0.8V
Return Loss	>15dB (270Mbits); >10dB (1.485Gbits)
Digital Video Outputs	
Signal	2 x Serial Digital Video (SDI) SMPTE 292M, 259M, 424M
Output Impedance	75 Ω
Output Level	0.8V pp +/- 10%
Return Loss	> 15dB (1.5 GHz)
Connection	BNC
Jitter	< 0.2 UI (Timing Jitter); (270MHz) < 0.2 UI (Alignment Jitter); < 1.0 UI (Timing Jitter); (1.485GHz) < 0.3 UI (Alignment Jitter); < 2.0 UI (Timing Jitter); (2.97GHz)
Analog Audio Inputs	
Signal	Up to 2 x balanced analog stereo inputs
Connectors	25 pin Sub D
Impedance	20 k Ω
Sampling / Quantization	48kHz / 24Bit
Noise floor	< -90dB (A-weighted)
Distortion	< 0.002% @ 20Hz to 20kHz
Frequency response	0.1dB @ 20Hz to 20kHz
Full Scale Level	12, 15, 18, 22 or 24 dBu
Analog Audio Outputs	
Signal	Up to 2 x balanced analog stereo outputs
Connector	25 pin SubD
Dynamic Range	>90dB
Signal to Noise	>85dB
Conversion	24 bit
Performance	
Audio Group Deletion	Existing groups pass transparently or they can be deleted and/or replaced with new embedded audio (user selectable)
Audio Group Selection	Map AES inputs into any of the 4 embedded audio groups
Audio Crossbar	Mono crossbar allows for individual (left and right) channel mapping <i>(Note. Mono crossbar only accessible via control system GUI, local control provides a AES (stereo pair) crossbar functionality)</i>
Electrical	
Operating Voltage	+ 12 VDC
Power Consumption	5W
Safety	IEC 950 / EN 60950 / VDE 0805
Mechanical	
Size	283mm x 78mm
Weight	CardModule 120g, connector plate 70g
Ambient	
Temperature	5°C – 40°C Maintaining Specifications
Humidity	90% non condensing

Service

Parts List

Due to the very dense design and high level of integration there the module is not user serviceable. Please contact LYNX for repairs or to request an exchange unit.

Technical Support

If you are experiencing problems, or have questions please contact your local distributor for further assistance.

Technical support is also available from our website.

Please do not return products to LYNX without an RMA. Contact your authorized dealer or reseller for more details on our return process.

More detailed product information and product updates may be available on our web site:

www.lynx-technik.com

Contact Information

Please contact your local distributor; this is your local and fastest method for obtaining support and sales information.

LYNX Technik can be contacted directly using the information below.

Address LYNX Technik AG
 Brunnenweg 3
 D-64331 Weiterstadt
 Germany

Website www.lynx-technik.com

E-Mail info@lynx-technik.com

LYNX Technik manufactures a complete range of high quality modular products for broadcast and Professional markets, please contact your local representative or visit our web site for more product information.

LYNXTechnik **AG**[®]
Broadcast Television Equipment